

双 16x16 ECL 矩阵开关 – KSD0490

650 Mbit



TECHNICAL DATA @ 25°C

Part No.	1500039
Number of inputs	
Data	16, differential
Clock	16, differential
Number of outputs	
Data	16, differential
Clock	16, differential
Architecture	Non-blocking, full fan-out, switching: solid state cross-point switches
Data rate [Mbit]	650 min.
Signal type	
Input	NECL (Data & Clock)
Output	NECL (Data & Clock)
Termination	
Input	50Ω to -2V (Vtt)
Output	none ("far-termination" 50Ω to -2V is required)
Propag. delay [ns]	1.8 typ.
Impedance [Ω]	50 (nominal)
Connectors	
Input	SMA female (Data & Clock)
Output	SMA female (Data & Clock)

Local control	LC display and keyboard, front panel
Remote control	RJ45 Ethernet port 10/100 Base T. TCP/IP & UDP, SNMP , GUI (browser interface) RS-232/422/485 interface (selectable)
Power supply	90-264 V AC (50/60 Hz)
AC consumption	50VA max.
Temperature range	Indoor use only
Operating	0 ... +40°C
Storage	-10 ... +60°C
Colour:	Front panel: RAL7032
Attached hardware	Power cord Operating manual
Dimensions (wxhxd)	483mm x 266mm x 420mm (19" drawer, 6U)
Weight	9 kg
Features	<ul style="list-style-type: none"> ▪ Redundant power supply ▪ Internal negative ECL voltage is adjustable (Vtt)

OPTIONS

The following options are available:

- Single power supply
- SNMP (protocol version 1)
- Unbalanced ins and/or outs
- Other connectors



DESCRIPTION

The ECL Switch Matrix provides a solution to complex signal routing problems. It accepts data and clock inputs and routes them to the desired outputs. The matrix provides full fan-out operation, allowing each input to be routed to any or all outputs simultaneously. The system is also non-blocking, meaning that any number of input and output combinations can be connected.

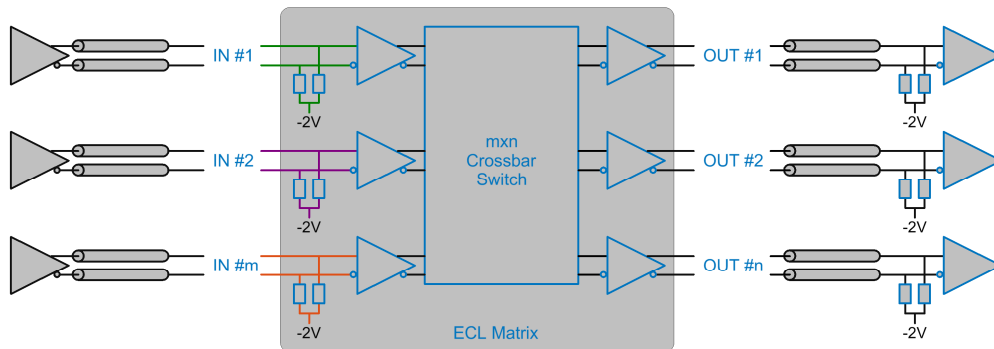

The KSD0490 is capable of switching data rates up to at least 650 Mbit.

The system supports come with serial and Ethernet control interfaces, allowing setup flexibility and easy remote test management.

APPLICATIONS

- Data acquisition
- Telemetry
- Test laboratories
- ATE stations

ABOUT US

novotronic is a Germany-based electronics engineering company. **novotronic** specialises in meeting the needs of government and defence, telecommunication, broadcast and aerospace. We have about 25 years experience producing state of the art technology for your applications.

OUR SKILLS

novotronic develops and manufactures technically sophisticated products. As a **certified aerospace and defence company novotronic** operates a quality management system in accordance with ISO 9001:2015 and EN 9100:2018 (equivalent to AS 9100D and JISQ 9100:2016 including ISO 9001:2015).



关注测试专家



hkaco.com